

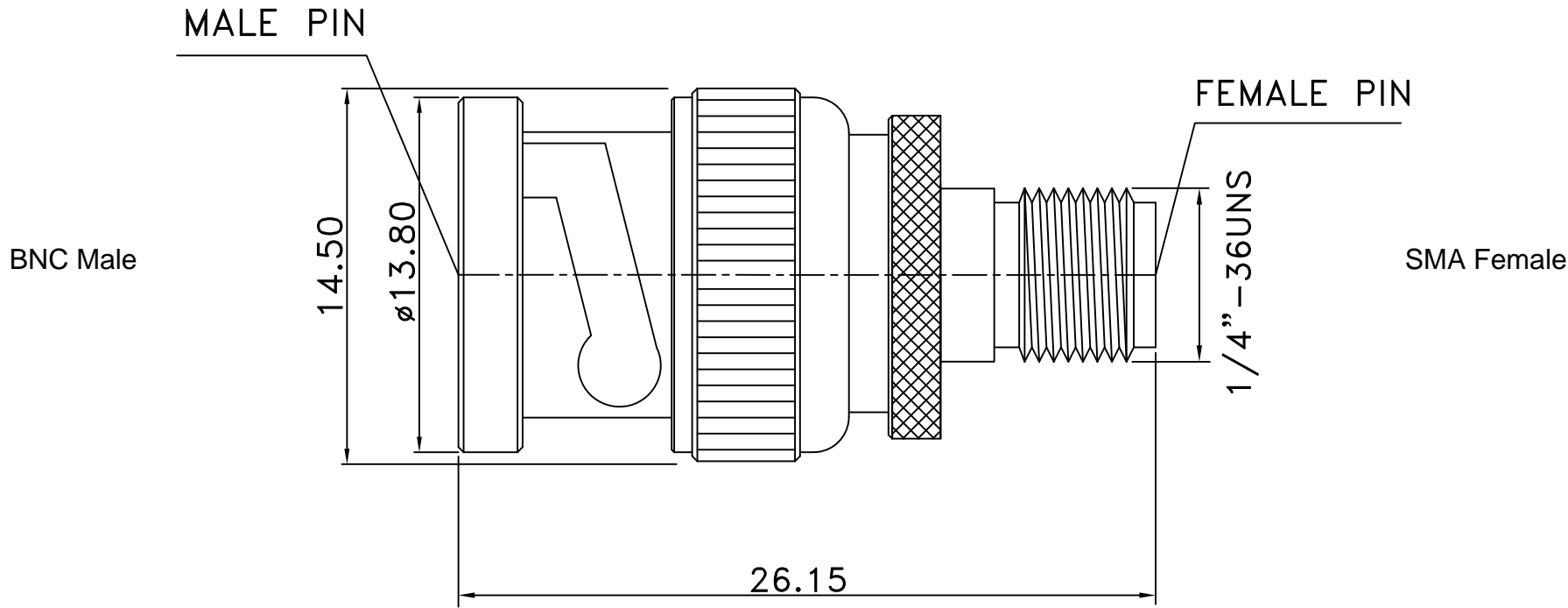

REV	DESCRIPTION	DRAWN	DATE



7	SPRING	1	SK-5	NICKEL
6	WASHER	1	IRON	NICKEL
5	SHELL	1	BRASS	NICKEL
4	GASKET	1	RUBBER	NONE
3	DIELECTRIC	1	TEFLON	NONE
2	PIN	2	BRASS	GOLD
1	BODY	1	BRASS	NICKEL
NO	Description	Qty	Material	Finish

UNLESS OTHERWISE SPECIFIED 1.REMOVE ALL BURRS. 2.BREAK ALL CONNERS & EDGES CO.15 MAX. 3.CHAMFER 1ST & LAST THREADS 45°. 4.DIAMETERS ON COMMON CENTERS. TO BE CONCENTRIC WITHIN 0.1 T.I.R. 5.ALL DIMENSIONS ARE AFTER PLATING.	* MAJOR DIMENSION		APPROVED	 Siretta <small>Enabling Industrial IoT</small>	
	UNLESS OTHERWISE NOTED TOLERANCES		CHECKED		
	0.5-6=±0.2 6-30=±0.4 30-120=±0.6 120-315=±1.0 ANGLES=±1°		DRAWN		
SCALE	4/1	UNIT	MM	DRAWN DATE	03/07/23
DRAWING NO.			ADAPT/SMAF/BNCM		REV
FILE NO.			A		